

# EPS Foam Densification System

Loose EPS Foam  
truckload weights of  
2,000 lbs.\*



Baled EPS Foam  
truckload weights of  
6,000 lbs.\*



\* Truckload weights listed are approximate

Densified EPS Foam truckload weights up to 40,000 lbs. \*

- Reduced handling costs and storage requirements
- Eliminates pentane gas dangers
- Up to 300 lbs per hour with 1.5# EPS
- Superior performance
- Minimal maintenance
- 15 to 22 lbs per cubic foot

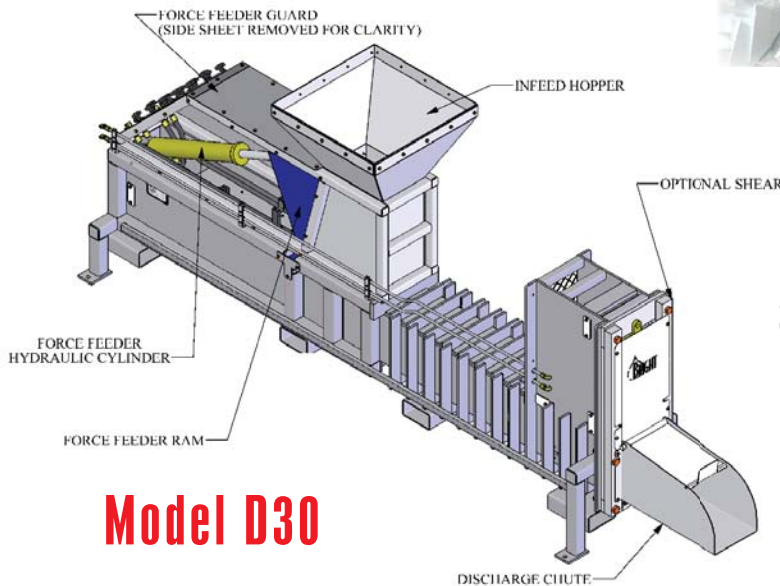

**Product Testing Available**

**1-800-253-0532 Toll Free US**

**1-269-793-7183 Phone**

**Watch the video**

**[www.densifiervideo.com](http://www.densifiervideo.com)**

Bright Technologies,  
Specialty Equipment div. of Sebright Products, Inc.  
127 N Water St.  
Hopkins, Michigan 49328  
800-253-0532 Toll Free US  
269-793-7183 Phone  
269-793-4022 Fax

**Working together to provide  
complete  
waste and recycle processing solutions**



**The Densification Specialists**

**Sebright**

Stationary Compactors  
Self-contained Compactors  
Precrushers  
Hydraulic Cart Dumpers, Custom Carts and Containers

Bright

Belt Filter Presses  
High Density Extruders  
Xtractors  
EPS Foam Densifiers

For more information, please visit our websites at  
[www.sebrightproducts.com](http://www.sebrightproducts.com) and  
[www.brightbeltpress.com](http://www.brightbeltpress.com)

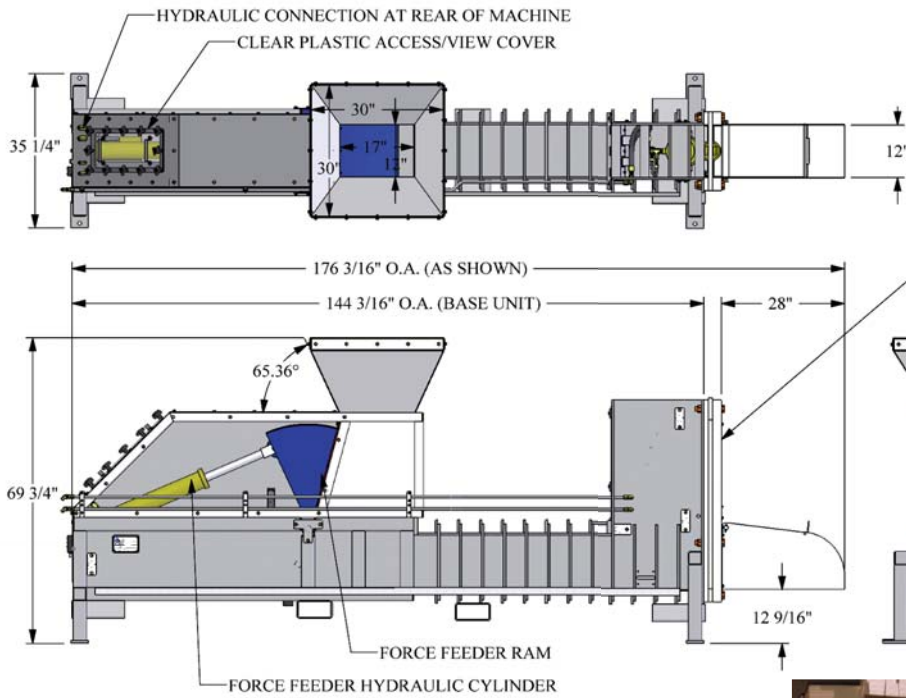

Ship This



Or Ship This



<b>Chamber Volume</b>	<b>Motor</b>	<b>Cylinder</b>	<b>Ram Force</b>	<b>Total Force</b>
.22 cu yards	15 HP	(1) 6" Diameter	490 PSI	71,000 lbs.
<b>Feed Capacity w/1.5# EPS</b>	<b>Volume Compaction Ratio</b>	<b>Output Density</b>	<b>Machine Weight</b>	<b>Power Unit Weight</b>
300 lbs. per hour	Up to 50:1	15-22 lbs./ft <sup>3</sup>	3,700 lbs.	1,250 lbs.

**Available options include:**

- elevation stands
- blower systems
- automated block shears
- discharge snout extensions
- customized EPS Foam pre-breakers
- bag house assemblies

Due to product improvements, the manufacturer reserves the right to alter or amend, without notice, any of these specifications and/or dimensions.

All machines and accessories are primer coated and finish painted. Standard color chart available upon request.

© Sebright Products, Inc. 2008



WASTEC  
Waste Equipment Technology Association  
Member

